

How To Pack

Rolling: By rolling your clothes, you crease them less. The fabric should recover by shaking it out. See illustrations.

Overnight Business Trip: If you are only taking a few things, you will not need to use all the pouches. You can use them for cushioning and packing other items you collect during your trip.

Longer Trips: Wear the biggest and bulkiest shoes, coats, etc. and pack the smaller items. Put rolled socks inside your packed shoes.

Shirts: Follow the illustrations. ZÜCA recommends the red pouch.

Pants: Fold pants lengthwise to reduce the waistline and width to about 10". Then start at the knees and begin rolling, using a double folded t-shirt or socks as a core.

Coats: If you are packing a sport or suit coat, roll it by double folding lengthwise so that the liner is showing and the sleeves are inside. Arrange the sleeves so they lay flat. Use another piece of clothing as the core and roll it up inside a Red pouch.

Don't forget to use your socks, under garments, etc. to fill up the empty areas of your packing pouches. If you can't leave without a dip in the pool or your laundry is still wet, shove your damp items into the vinyl-pocket inside the front door.

Fold & Roll

Dress Shirts & Coats

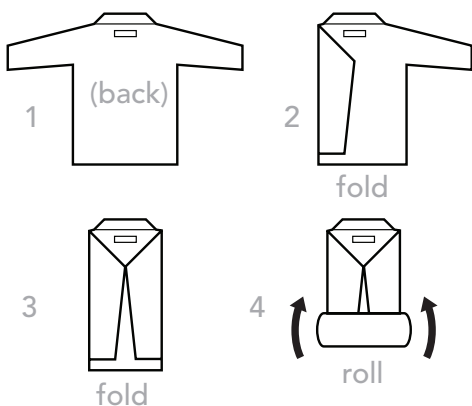

Skirts & Slacks

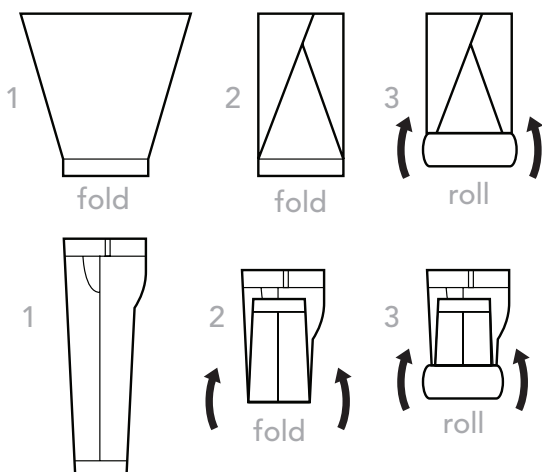

Roll up your shirts, skirts and slacks and place in pouches.

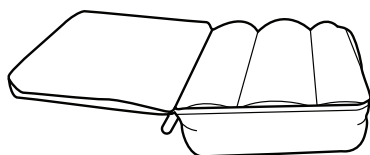

Pro Packing Tips

ZÜCA®



What's inside?

5 - Color coded pouches.

1 - Expandable vinyl pocket inside the front door. Pack with wet items like bathing suit or wet laundry.

1 - One-quart capacity, clear TSA compliant zipper pouch (found in the mesh pocket inside the roof of the ZÜCA.)

1 - Travel Cover (optional): to protect your ZÜCA in case you check your bag.

Color Coded Pouches...

Green (1) 9.5" wide and 8" long x 3" deep.
This is the bottom pouch because its shape fits forward of the wheels. Pack with socks, t-shirts, under garments.

Red (2) 9.5" wide and 10.5" long x 5" deep.
Pack with sweaters, shoes, shirts, pants, etc.

Blue (1) 9.5" wide and 10.5" long x 3" deep.
Pack with slacks, shorts, socks, PJs, etc.

Orange (1) - 9.5" wide and 10.5" long x 2" deep.
Pack with socks, under garments, ties, gloves, belts, etc.

TSA Tips

TSA only allows liquids or gels up to 3.4oz or 100ml bottles. It doesn't matter if you only have 1oz in a 5oz bottle, TSA will not allow it. We suggest you purchase a complete set of 3oz. sample size products. When possible, squeeze out the air, tighten the caps so the change in atmospheric pressure in the airplane doesn't burst your lotion or toothpaste. Don't forget to take the pouch out of your ZÜCA before it is screened.